

- 1 Adjusting Screw
- 2 Lock Nut
- 3 Identification Tag
- 4 Piping Chamber
- 5 Assembly Screw
- 6 Assembly Nut
- 7 Spring Button
- 8 Pressure Spring
- 9 Pressure Plate
- 10 Diaphragms
- 11 Gasket
- 12 Pusher Post Button
- 13 Body
- 14 Cylinder
- 15 Piston Assembly
- 16 Piston Spring
- 17 Strainer Screen
- 18 Gasket
- 19 Bottom Plug

DESCRIPTION

The Type B regulator is a fully automatic pressure regulating valve designed for cryogenic service in the pressure build-up circuit. Because the Type B may be used for either cryogenic liquids or gases, it may be installed either before or after the pressure build-up coil.

SPECIFICATION DATA

Service: Cryogenic liquids and gases (pressure reducing or pressure build-up service)

Sizes: 1/4", 3/8", 1/2", 3/4", 1", 1-1/4", 1-1/2" and 2"

Connections: Threaded (NPT) female inlet and outlet

Temperature Rating: +150°F (339°K) to -320°F (78°K)

Maximum Initial Pressure: 400 psi

Pressure Control Range: Per Spring Range Table

CONSTRUCTION

Bronze body, internal trim, and diaphragms; Teflon seat, diaphragm gasket, and bottom plug gasket; Silicon bronze bolts and nuts; Stainless steel pressure spring.

All parts commercially cleaned for cryogenic service.

GENERAL INSTALLATION INSTRUCTIONS

The Type B regulator may be installed in the horizontal position with the spring chamber up or down. For other installation requirements consult the factory. For ease of operation and maintenance, it is suggested that manual shut-off valves be installed upstream and downstream from the valve. Before installing the valve, all piping should be thoroughly flushed out to remove any foreign material. Install the valve with the inlet pipe fitted to the inlet connection identified on the valve body. Use a compatible sealant on the male pipe threads and do not overtighten the valve connections.

OPERATING INSTRUCTIONS

Adjusting the Delivery Pressure

The regulator's delivery pressure setting is adjusted by turning the adjusting screw (1) at the top of the spring chamber after loosening the adjusting screw lock nut (2). To increase the



Type B CRYOGENIC PRESSURE REGULATOR

This Page No.	TS-BCRY
Date Of This Issue	MAY 1998
Supersedes Page No.	TS-BCRY
Dated	MAY 1995

delivery pressure, turn the adjusting screw clockwise (into the spring chamber). To decrease the delivery pressure, turn the adjusting screw counter-clockwise (out of the spring chamber). Tighten the adjusting screw lock nut after the adjustment has been made.

MAINTENANCE INSTRUCTIONS

The following procedures are provided for servicing the recommended spare parts for the Type B regulator. Repair parts can easily be installed without removing the regulator from the line.

CAUTION: Before attempting to replace any spare parts be sure to shut off all pressure connections to the valve being serviced. Even with the valve closed, however, system pressure could still be locked between the shut-off valve and the inlet and/or outlet sides of the regulator. Before proceeding with any valve service be certain to relieve the pressure from BOTH sides of the regulator.

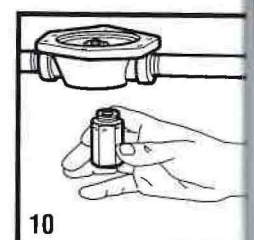
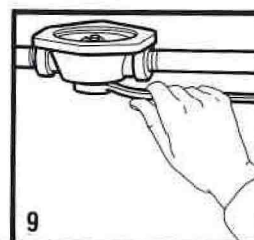
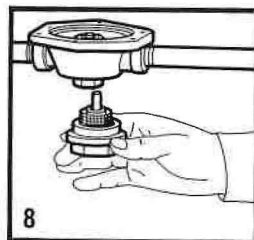
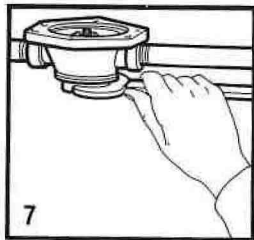
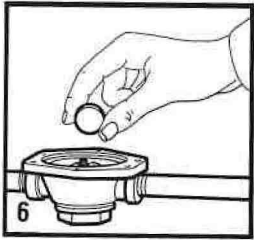
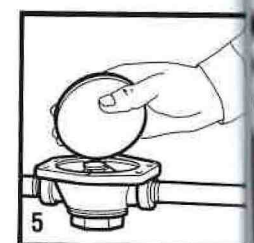
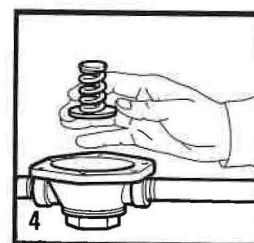
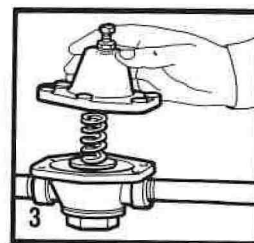
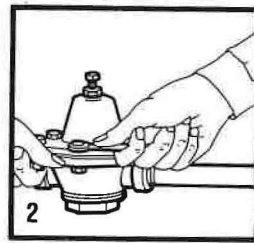
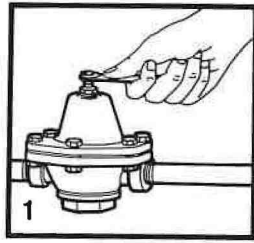

Refer to the Type B regulator exploded view for parts identification.

Servicing the Diaphragm Assembly (10) and Pressure Spring (8)

1. Loosen the lock nut (2) 1/4 turn and turn the adjusting screw (1) counter-clockwise until the pressure spring (8) is no longer under tension, Figure 1.
2. Remove the six assembly screws (5) and nuts (6) securing the spring chamber (4) to the valve body (13), Figure 2. During reassembly, tighten the screws evenly in an alternate diagonal pattern.
3. Lift the spring chamber (4) from the valve body, Figure 3. Then remove the spring button (7), pressure spring (8), and pressure plate (9), Figure 4. The pressure plate is **not** secured to the diaphragm.
4. Remove the Diaphragms (10), Figure 5, and the Teflon gasket (11) located under the diaphragms. Five metal diaphragms are used in valve sizes 1/4" through 3/4"; six are used in valve sizes 1" through 2".
5. Remove the pusher post button (12) from the protruding pusher post, Figure 6. During reassembly, be sure the pusher post button is centered properly on the pusher post.
6. Inspect all parts and replace if necessary. Reassemble the parts in reverse order.

Servicing the Cylinder (14), Piston (15), Strainer Screen (17), and Bottom Plug Gasket (18)

1. It is important that the load on the pressure spring (9) be relieved before attempting to service any parts through the bottom of the valve. Relieve the pressure spring tension as detailed in Step 1 under Servicing the Diaphragm Assembly (10) and pressure spring (8), above.
2. Remove the bottom plug (19) as follows:

1/4" through 1-1/2" valves: The bottom plug is under slight tension as a result of the piston spring (16) acting against the plug. Loosen the bottom plug with a standard wrench, Figure 7, then carefully unscrew the plug by hand. The piston (15), piston spring (16), and strainer screen (17) will normally "drift" out with the bottom plug.

2" valves: Remove the 6 screws retaining the bottom plug (19) to the valve body. Next, carefully remove the two cylinder plate screws and the cylinder plate. The piston (15), piston spring (16), and strainer screen (17) can now be removed.

NOTE: The Teflon bottom plug gasket (18) not only provides a tight seal but also assures easy removal of the bottom plug by preventing sticking or bonding of the plug to the valve body.

3. Thoroughly clean the strainer screen and flush the valve body to remove any foreign material that may have collected around the strainer screen.
4. Unscrew the hexagon cylinder (14) from the valve body with a socket wrench, Figure 9, to prevent distortion. Note that the cylinder extends below the face of the valve body to permit convenient removal.
5. Inspect all parts and replace if necessary. Should either the cylinder (14), Figure 10, or the piston (15) need replacing, then it will be necessary to replace **both** parts because both parts wear equally.
6. Reassemble the valve in reverse order. After placing the valve in service, readjust the delivery pressure as detailed under Operating Instructions.

REPAIR PARTS INFORMATION

Refer to the exploded view of the Type B regulator for parts identification.

VPS B REPAIR KITS

KIT NUMBER	PIPE SIZE	VALVE NUMBER	DIAPHRAGM	DIAPHRAGM GASKET	PISTON ASSEMBLY	CYLINDER	BOTTOM PLUG GASKET
12368	1/4"	12315	1632	12308	8597	1933	7984
12369	3/8"	12316	1763	12309	8598	1934	7984
12300	1/2"	12317	1580	12311	12394	1935	3109
13068	1/2"	12290	1580	12311	12294	12293	3109
13065	3/4"	12300	1582	12312	12294	12293	3109
12302	1"	12319	1781	12297	7795	1936	4068
13050	1-1/4"	12320	1802	12326	8561	1938	4068
13050	1-1/2"	12321	1802	12326	8561	1938	4068
10541	2"	8580	1834	18627	8576	1824	8578

SPECIFICATIONS

Each Type B pressure regulator is equipped with a pressure spring selected to provide the needed outlet or reduced pressure setting. The range of adjustment or satisfactory "working range" of individual springs is shown below for each valve size. Every regulator has the "set" pressure and range of adjustment stamped on a tag fastened to the valve. The ranges shown below are recommended for best performance.

SPRING RANGES

SIZE	SPRING NUMBER AND ADJUSTMENT RANGE (psi)					
1/4"	#4765 10-30	#7337 25-100	#8741 50-200	#10661 100-250	-	-
3/8"	#11143 20-50	#8691 40-150	#8683 100-225	#14301 100-250	-	-
1/2"	#11143 10-30	#10016 20-75	#10017 25-125	#10018 100-200	#10019 150-250	-
3/4"	#11143 10-30	#10016 20-70	#10017 30-100	#10018 50-150	#10019 100-225	#9983 150-250
1"	#8484 10-35	#8485 20-60	#8486 50-100	#8487 100-250	-	-
1-1/4"	#8484 10-30	#8485 20-40	#8486 35-80	#8487 75-150	-	-
1-1/2"	#8484 10-30	#8485 20-40	#8486 35-80	#8487 75-150	-	-
2"	#6301 10-20	#8773 10-50	#12913 20-100	-	-	-

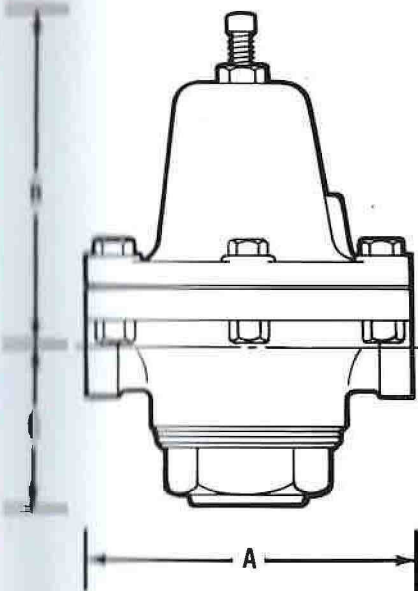

DIMENSIONS

VALVE SIZE	DIMENSIONS			SHIP. WT. (lbs)
	A	B	A	
1/4"	3"	2-7/8"	1-3/4"	3
3/8"	3-7/8"	4-1/2"	1-3/4"	5-1/2
1/2"	4-1/2"	4-1/2"	2-1/8"	8
3/4"	5-1/8"	4-5/8"	2-1/8"	10
1"	5-7/8"	5-3/8"	2-1/8"	16
1-1/4"	6-3/4"	6-1/8"	2-5/8"	20
1-1/2"	6-3/4"	6-1/8"	2-5/8"	20
2"	9-1/4"	8-1/2"	3-1/2"	37

HOW TO ORDER

Convenient, pre-packaged repair kits are available for the Type B regulators. Each kit includes diaphragm(s), diaphragm gasket, piston assembly, cylinder, strainer screen, piston spring and bottom plug gasket. The kits may be ordered by kit number as listed.

To order repair parts, refer to the exploded view of the Type B regulator to identify the part required. When ordering please use the part

names listed and provide the valve serial number stated on the identification tag. Also state the following:

"Repair Parts for Type B Cryogenic Regulator" and provide:

1. Valve size
2. Service
3. Inlet pressure
4. Outlet or delivery pressure range and setting
5. Part description
6. Part number if stated
7. Quantity of each part
8. Valve assembly or serial number stated on the metal identification tag under the adjusting screw lock nut.



IMI CASH VALVE INC.

2400 7TH AVENUE SW • CULLMAN, ALABAMA 35055
1-800-879-2042 • FAX 1-800-879-2057
205-775-8200 • FAX 205-775-8238

IMI

© 1997 IMI CASH VALVE INC.

TECHSPEC

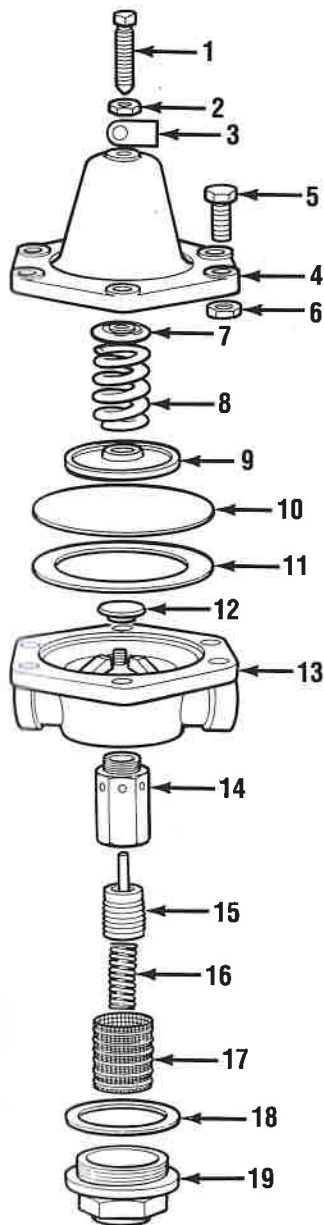

- 1 Adjusting Screw
- 2 Lock Nut
- 3 Identification Tag
- 4 Spring Chamber
- 5 Assembly Screw
- 6 Assembly Nut
- 7 Spring Button
- 8 Pressure Spring
- 9 Pressure Plate
- 10 Diaphragms
- 11 Gasket
- 12 Pusher Post Button
- 13 Body
- 14 Cylinder
- 15 Piston Assembly
- 16 Piston Spring
- 17 Strainer Screen
- 18 Gasket
- 19 Bottom Plug

DESCRIPTION

The Type B regulator is a fully automatic pressure regulating valve designed for cryogenic service in the pressure build-up circuit. Because the Type B may be used for either cryogenic liquids or gases, it may be installed either before or after the pressure build-up coil.

SPECIFICATION DATA

Service: Cryogenic liquids and gases (pressure reducing or pressure build-up service)

Sizes: 1/4", 3/8", 1/2", 3/4", 1", 1-1/4", 1-1/2" and 2"

Connections: Threaded (NPT) female inlet and outlet

Temperature Rating: +150°F (339°K) to -320°F (78°K)

Maximum Initial Pressure: 400 psi

Pressure Control Range: Per Spring Range Table

CONSTRUCTION

Bronze body, internal trim, and diaphragms; Teflon seat, diaphragm gasket, and bottom plug gasket; Silicon bronze bolts and nuts; Stainless steel pressure spring.

All parts commercially cleaned for cryogenic service.

GENERAL INSTALLATION INSTRUCTIONS

The Type B regulator may be installed in the horizontal position with the spring chamber up or down. For other installation requirements consult the factory. For ease of operation and maintenance, it is suggested that manual shut-off valves be installed upstream and downstream from the valve. Before installing the valve, all piping should be thoroughly flushed out to remove any foreign material. Install the valve with the inlet pipe fitted to the inlet connection identified on the valve body. Use a compatible sealant on the male pipe threads and do not overtighten the valve connections.

OPERATING INSTRUCTIONS

Adjusting the Delivery Pressure

The regulator's delivery pressure setting is adjusted by turning the adjusting screw (1) at the top of the spring chamber after loosening the adjusting screw lock nut (2). To increase the



Type B CRYOGENIC PRESSURE REGULATOR

This Page No.	TS-BCRY
Date Of This Issue	MAY 1998
Supersedes Page No.	TS-BCRY
Dated	MAY 1995

delivery pressure, turn the adjusting screw clockwise (into the spring chamber). To decrease the delivery pressure, turn the adjusting screw counter-clockwise (out of the spring chamber). Tighten the adjusting screw lock nut after the adjustment has been made.

MAINTENANCE INSTRUCTIONS

The following procedures are provided for servicing the recommended spare parts for the Type B regulator. Repair parts can easily be installed without removing the regulator from the line.

CAUTION: Before attempting to replace any spare parts be sure to shut off all pressure connections to the valve being serviced. Even with the valve closed, however, system pressure could still be locked between the shut-off valve and the inlet and/or outlet sides of the regulator. Before proceeding with any valve service be certain to relieve the pressure from BOTH sides of the regulator.

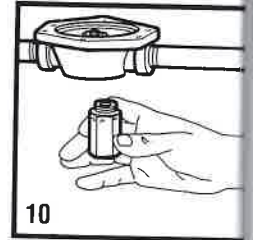
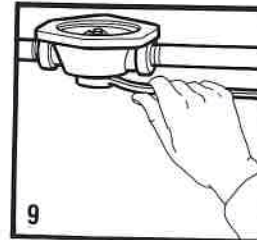
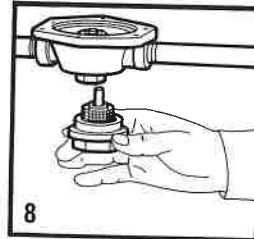
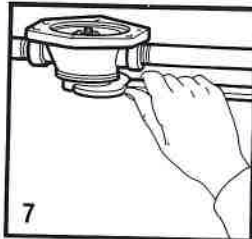
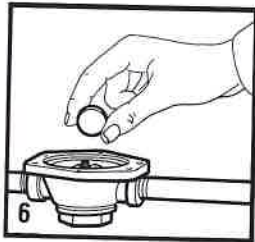
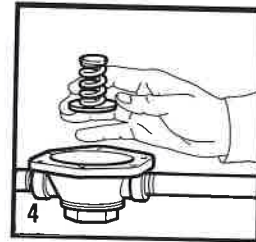
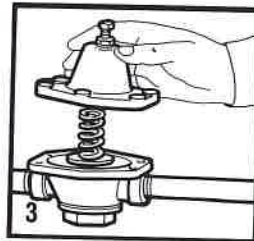
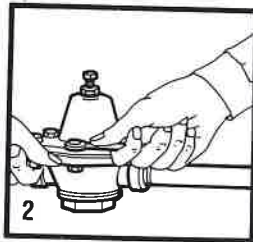
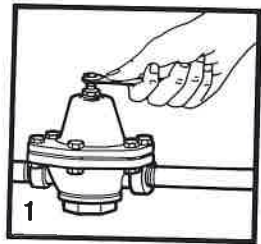

Refer to the Type B regulator exploded view for parts identification.

Servicing the Diaphragm Assembly (10) and Pressure Spring (8)

- Loosen the lock nut (2) 1/4 turn and turn the adjusting screw (1) counter-clockwise until the pressure spring (8) is no longer under tension, Figure 1.
- Remove the six assembly screws (5) and nuts (6) securing the spring chamber (4) to the valve body (13), Figure 2. During reassembly, tighten the screws evenly in an alternate diagonal pattern.
- Lift the spring chamber (4) from the valve body, Figure 3. Then remove the spring button (7), pressure spring (8), and pressure plate (9), Figure 4. The pressure plate is **not** secured to the diaphragm.
- Remove the Diaphragms (10), Figure 5, and the Teflon gasket (11) located under the diaphragms. Five metal diaphragms are used in valve sizes 1/4" through 3/4"; six are used in valve sizes 1" through 2".
- Remove the pusher post button (12) from the protruding pusher post, Figure 6. During reassembly, be sure the pusher post button is centered properly on the pusher post.
- Inspect all parts and replace if necessary. Reassemble the parts in reverse order.

Servicing the Cylinder (14), Piston (15), Strainer Screen (17), and Bottom Plug Gasket (18)

- It is important that the load on the pressure spring (9) be relieved before attempting to service any parts through the bottom of the valve. Relieve the pressure spring tension as detailed in Step 1 under Servicing the Diaphragm Assembly (10) and pressure spring (8), above.
- Remove the bottom plug (19) as follows:

1/4" through 1-1/2" valves: The bottom plug is under slight tension as a result of the piston spring (16) acting against the plug. Loosen the bottom plug with a standard wrench, Figure 7, then carefully unscrew the plug by hand. The piston (15), piston spring (16), and strainer screen (17) will normally "drift" out with the bottom plug.

2" valves: Remove the 6 screws retaining the bottom plug (19) to the valve body. Next, carefully remove the two cylinder plate screws and the cylinder plate. The piston (15), piston spring (16), and strainer screen (17) can now be removed.

NOTE: The Teflon bottom plug gasket (18) not only provides a tight seal but also assures easy removal of the bottom plug by preventing sticking or bonding of the plug to the valve body.

- Thoroughly clean the strainer screen and flush the valve body to remove any foreign material that may have collected around the strainer screen.
- Unscrew the hexagon cylinder (14) from the valve body with a socket wrench, Figure 9, to prevent distortion. Note that the cylinder extends below the face of the valve body to permit convenient removal.
- Inspect all parts and replace if necessary. Should either the cylinder (14), Figure 10, or the piston (15) need replacing, then it will be necessary to replace **both** parts because both parts wear equally.
- Reassemble the valve in reverse order. After placing the valve in service, readjust the delivery pressure as detailed under Operating Instructions.

REPAIR PARTS INFORMATION

Refer to the exploded view of the Type B regulator for parts identification.

TYPE B REPAIR KITS

KIT NUMBER	PIPE SIZE	VALVE NUMBER	DIAPHRAGM	DIAPHRAGM GASKET	PISTON ASSEMBLY	CYLINDER	BOTTOM PLUG GASKET
12358	1/4"	12315	1632	12308	8597	1933	7984
12359	3/8"	12316	1763	12309	8598	1934	7984
12360	1/2"	12317	1580	12311	12394	1935	3109
13068	1/2"	12290	1580	12311	12294	12293	3109
13065	3/4"	12300	1582	12312	12294	12293	3109
12302	1"	12319	1781	12297	7795	1936	4068
13060	1-1/4"	12320	1802	12326	8561	1938	4068
13060	1-1/2"	12321	1802	12326	8561	1938	4068
10541	2"	8580	1834	18627	8576	1824	8578

SPECIFICATIONS

Each Type B pressure regulator is equipped with a pressure spring selected to provide the desired outlet or reduced pressure setting. The range of adjustment or satisfactory "working range" of individual springs is shown below for each valve size. Every regulator has the "set" pressure and range of adjustment stamped on a tag fastened to the valve. The ranges shown below are recommended for best performance.

SPRING RANGES

SIZE	SPRING NUMBER AND ADJUSTMENT RANGE (psi)					
1/4"	#4765 10-30	#7337 25-100	#8741 50-200	#10661 100-250	-	-
3/8"	#11143 20-50	#8691 40-150	#8683 100-225	#14301 100-250	-	-
1/2"	#11143 10-30	#10016 20-75	#10017 25-125	#10018 100-200	#10019 150-250	-
3/4"	#11143 10-30	#10016 20-70	#10017 30-100	#10018 50-150	#10019 100-225	#9983 150-250
1"	#8484 10-35	#8485 20-60	#8486 50-100	#8487 100-250	-	-
1-1/4"	#8484 10-30	#8485 20-40	#8486 35-80	#8487 75-150	-	-
1-1/2"	#8484 10-30	#8485 20-40	#8486 35-80	#8487 75-150	-	-
2"	#6301 10-20	#8773 10-50	#12913 20-100	-	-	-

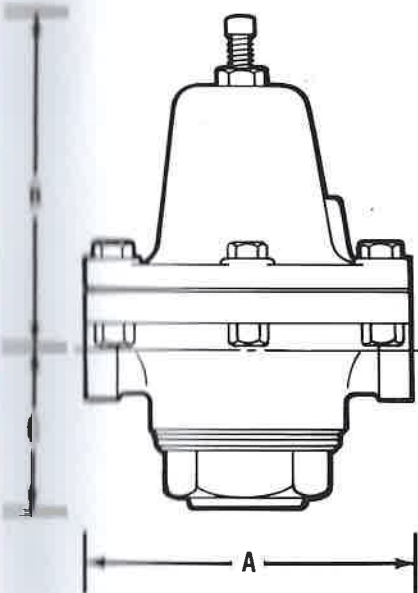

DIMENSIONS

VALVE SIZE	DIMENSIONS			SHIP. WT. (lbs)
	A	B	A	
1/4"	3"	2-7/8"	1-3/4"	3
3/8"	3-7/8"	4-1/2"	1-3/4"	5-1/2
1/2"	4-1/2"	4-1/2"	2-1/8"	8
3/4"	5-1/8"	4-5/8"	2-1/8"	10
1"	5-7/8"	5-3/8"	2-1/8"	16
1-1/4"	6-3/4"	6-1/8"	2-5/8"	20
1-1/2"	6-3/4"	6-1/8"	2-5/8"	20
2"	9-1/4"	8-1/2"	3-1/2"	37

HOW TO ORDER

Convenient, pre-packaged repair kits are available for the Type B regulators. Each kit includes diaphragm(s), diaphragm gasket, piston assembly, cylinder, strainer screen, piston spring and bottom plug gasket. The kits may be ordered by kit number as listed.

To order repair parts, refer to the exploded view of the Type B regulator to identify the part required. When ordering please use the part

names listed and provide the valve serial number stated on the identification tag. Also state the following:

"Repair Parts for Type B Cryogenic Regulator" and provide:

1. Valve size
2. Service
3. Inlet pressure

4. Outlet or delivery pressure range and setting
5. Part description
6. Part number if stated
7. Quantity of each part
8. Valve assembly or serial number stated on the metal identification tag under the adjusting screw lock nut.



IMI CASH VALVE INC.

2400 7TH AVENUE SW • CULLMAN, ALABAMA 35055
1-800-879-2042 • FAX 1-800-879-2057
205-775-8200 • FAX 205-775-8238

IMI

© 1997 IMI CASH VALVE INC.

1 Ad
2 Lo
3 Mid
4 Hi
5 Av
6 Sp
7 Pr
8 Pu
9 Lo
10 Pr
11 Di